

# Test Server

## SMART SERVER & SORTER

- Electrical pusher for PCBs insertion into rack
- Electrical expeller for automatic PCBs insertion in line
- Extended SMEMA interface
- Good/bad sorting



ORDER CODE: 2-AOI; 2-AOIL; 2-AOIS; 2-AOISPT

### DETAILED FEATURES

	AOI	AOIL	AOIS	AOISPT
PCB length mm	100 ÷ 450	100 ÷ 450	100 ÷ 450	100 ÷ 450
PCB width mm	85 ÷ 330	88 ÷ 330	88 ÷ 330	85 ÷ 330
Height (with rack)	1065 (1550) mm	1065 (1550) mm	1065 (1550) mm	1065 (1550) mm
Length with rack	1690 mm	2180 mm	2180 mm	1690 mm
Air pressure	-	0,6 MPa	0,6 MPa	-

### PCB DIMENSIONS

Thickness	0,8 to 2,6 mm
Above board max height	40 mm
Below board max height	20 mm
Transport edge width	SMEMA 3 mm

### RACK HANDLING

Buffer capacity	1-2 rack
Maximum load	30 kg
PCB step height	10, 20, 30, 40 mm
Max rack dimensions	460x400x563 mm (LxWxH)
Max nr. PCB per rack	50

### PCB HANDLING

PCB transport system	Antistatic flat belt
Width adjustment	Manual
Length of conveyor sections	600 mm
Transport height	SMEMA 950 ± 25 mm
PCB flow direction	SMEMA left to right reverse flow optional
Cycle time	< 9"

### ELECTRICAL

Control type	PLC
Interface type	SMEMA (other types optional)
Human Machine Interface	Control panel with push-buttons, switches and light indicator
Voltage	230 V single phase, 50 Hz
Max power	165 W

### DIMENSIONS

Depth	660 mm
Max Mass	50/98 kg
Structure	Self-standing steel bodywork
Transparent material	Polycarbonate

LOADER - UNLOADER

CONVEYOR

TRAFFIC CONTROLLER

BUFFER

### Test AOI Server (Stand Alone)

Automatic PCB loading into AOI system with post – test and automatic unloading in the original rack slot.

ORDER CODE: 2-AOI

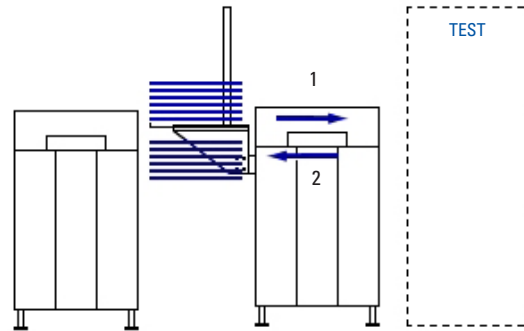

### Test Sorter (End Of Line)

Automatic PCB sorting according to the AOI testing results with selective unloading of PCBs into good or bad rack.

ORDER CODE: 2-AOIL

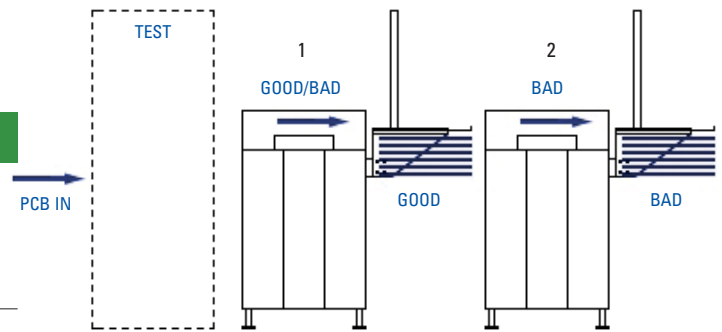

### Test Sorter Stand Alone (Pass-Back)

Automatic loading of each PCB on the AOI, automatic sorting of PCBs according to the AOI testing result and unloading of PCBs in different racks (good/bad).

ORDER CODE: 2-AOIS

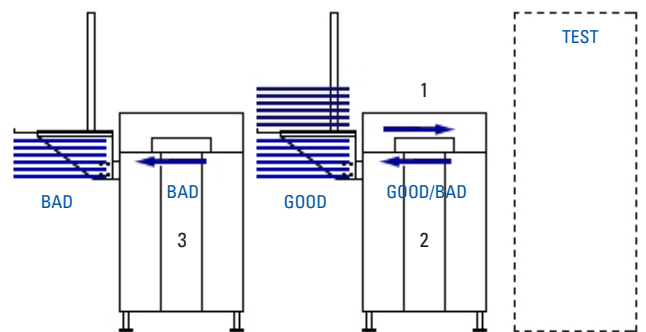

### Test Sorter Stand Alone (Pass-Through)

Automatic PCB loading into AOI system with automatic sorting of PCBs according to the AOI testing results and selective unloading or feeding.

ORDER CODE: 2-AOISPT

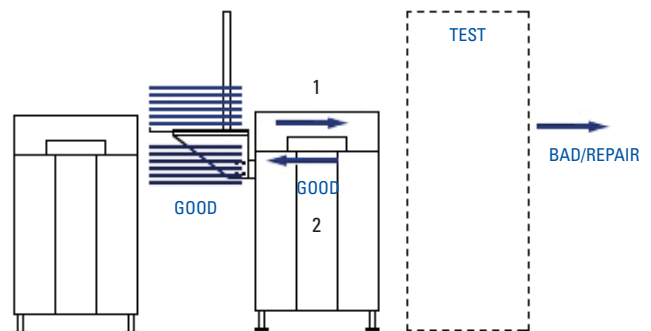

E-2-AOI-A

	LOADER - UNLOADER	CONVEYOR	TRAFFIC CONTROLLER	BUFFER	
--	-------------------	----------	--------------------	--------	--